



Stealth 207

Product Capacity/Speed:

Width: Up to 21" (53cm) / Speed: 550 (167m) or Optional 1100 (335m) LFPM

Linemods Premium Inkjet/Dryer Base - Quality without compromise, from the innovative vacuum system to the powder coated aluminum frames. Perform quick, easy setups – Linemods “Stealth” systems incorporate our patented “I Series” transport design with a separate driven dryer section –

PROVIDES “WIDE BELT” THROUGHPUT AND EDGE CONSISTENCY – WITHOUT THE WIDEBELT COSTS

Attributes:

- .5mm belt height (from deck)
- Ink resistant belts (Inkjet Section)
- Laser straight channeled conveyance
- Advanced technology vacuum system
- Premium Silicone dryer belts
- 1/2" Powder coated aluminum frames
- Adj. height +5" (12.7cm) from casters
- Tool-less adjustments
- Cantilevered discharge
- Adjustment scales
- Built-in encoder location
- I/O: Start, stop, feed and speed
- Dryer interlock



Vacuum system is engineered for application:

- Quiet
- Powerful
- Stall-resistant
- Efficient
- Expandable

Linemods equipment is designed with a balance of easy operation, longevity and innovation from over 25 years of experience in the post press/production environment – All equipment equipped with a 2-year built-in warranty.

Design:

- ✓ Minimal tools needed to perform most set-ups/changeovers
- ✓ Vacuum belt construction is of a friction resistant backer with a 55D Urethane cover, perforated for vacuum integration – Timing belts provide skew free operation on the inkjet section
- ✓ Vacuum system is engineered to provide optimal pull-down without stalling
- ✓ Dryer section belts are endless premium silicone
- ✓ Component design – All pivot points have bearings - expense not a factor in assembly – all components designed to last.
- ✓ 2-year warranty – We are confident with our parts/equipment designs and back new equipment with a 2-yr. warranty.

System Details:



All Linemods “Stealth” units are performance engineered to deliver an optimum supply of vacuum without stalling conveyor or stressing pump – We use regenerative vane vacuum system with pressure sensors to precisely control the vacuum pressure – Linemods offers the most innovative, high performance vacuum conveyor systems available.

Feature attributes:

- Solid construction
- Simple electrical/drive components
- Vacuum consistency
- Flush mount electrical enclosure

“I” Series Vacuum Transport Design:

I Series transports are built in two standard lengths 2' & 4' - We dedicate the transport belts common/uncommon sheet/book sizes from envelopes to very wide format sheets/books – Transport design is self-tensioning and worry free – We have many prearranged systems, also able to quickly and efficiently build to fit your exact needs.

- Max deck speed: 550 (167m) or 1100 (335m) LFPM
- Product thickness range: Parchment paper to ½” (13mm)
- Product width range: 1” (2.5cm) – 21” (53cm)
- Inkjet section max belt temp: 135 F/ 57 C
- Dryer section max belt temp: 400 F/ 205 C

- Gross weight: 765 lbs
- Electrical Requirement: 200-230v 1 Ph / 25amps

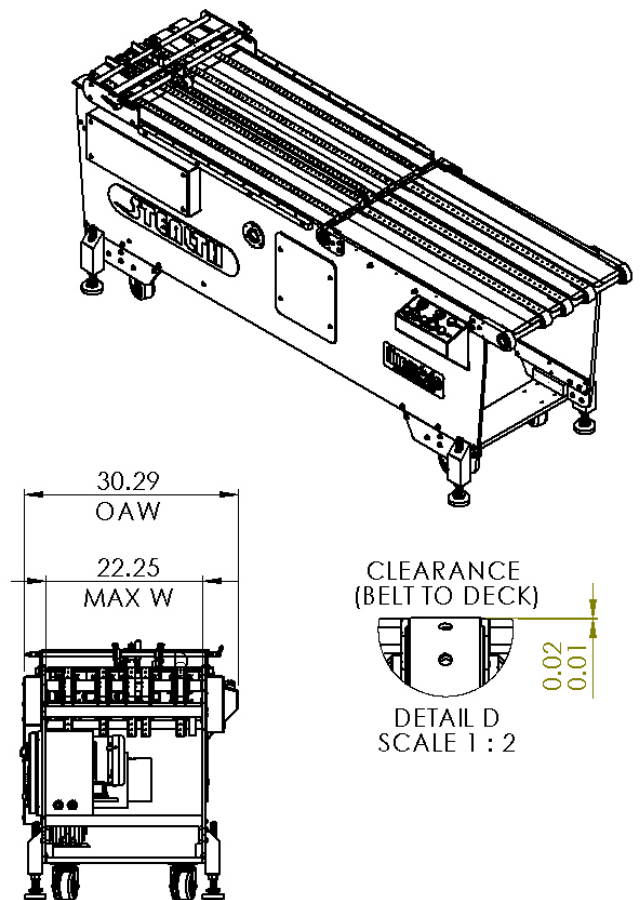
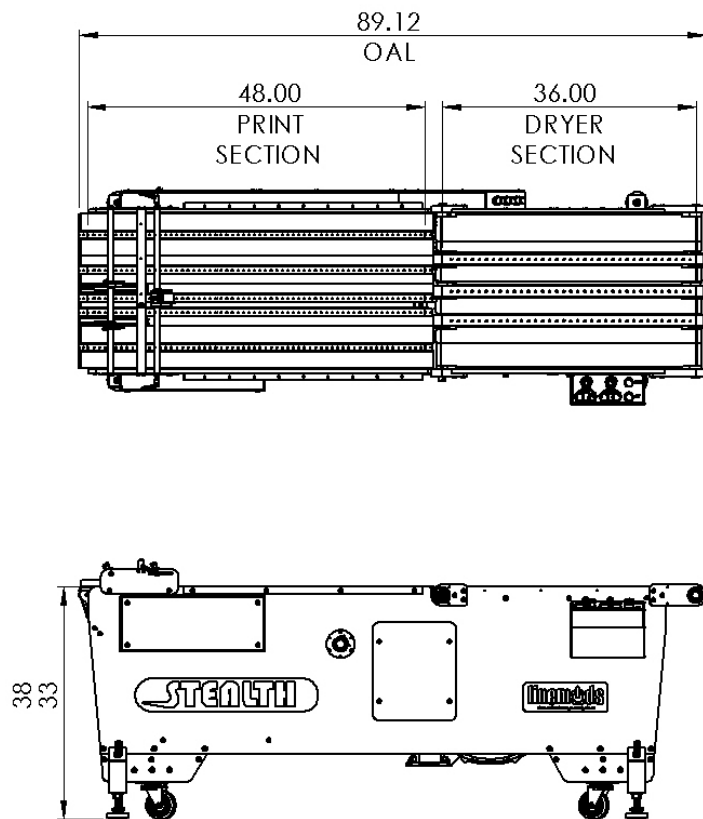

We can create equipment to fit your needs with optional colors, deck heights, segment configurations, and special guarding.